

1160 Hoftrac



WEIDEMANN
designed for work



1160 Technical specifications

Engine data (Standard)

Manufacturer	Perkins
Engine type	403 J-11
Cylinders	3
Engine performance (max.)	18,4 (25) kW (hp)
at rpm (max.)	2800 rpm
Cubic capacity	1131 cm ³
Cooling system	Water
Emissions standard level	V
Exhaust after treatment	-

Electrical system

Operating voltage	12 V
Alternator	40 (65) A
Weights	
Operating weight (standard)	1910-2250* kg
Tipping load with bucket - machine straight	905 kg
Tipping load with bucket - machine articulated	660 kg
Tipping load with pallet fork - machine straight	718 kg
Tipping load with pallet fork - machine articulated	521 kg
Vehicle data	
Axle (optional)	K80 (T80, T94)
Cab (optional)	FSD (eps)
Ground speed (optional)	0 - 13 (20, 30) km/h
Speed stages (optional)	1 (2)
Fuel tank capacity	20 l
Hydraulic oil tank capacity	20 l
Hydraulic system	
External services - Operating pressure	305 (450) bar
Steering hydraulics - Oil flow (optional)	30.8 l/min
Steering hydraulics - Operating pressure	225 bar
Drive	
Type of drive	Hydrostatic
Traction drive (optional)	Oil engine
Noise values	
Average sound power level L _{wA}	98.8 dB(A)
Guaranteed sound power level L _{wA}	101 dB(A)
Specified sound pressure level L _{pA}	85 dB(A)

*Tipping load with a cast rear counterweight

Tipping load calculation according to ISO 14397

FSD = canopy

eps = Easy Protection System (fold-down canopy)

Vibrations (weighted average effective value)

Hand-arm vibrations: The hand-arm vibrations are no more than 2.5 m/s²

Whole body vibrations: This machine is equipped with a driver's seat that meets the requirements of EN ISO 7096:2000.

When the loader is properly used, the whole body vibrations vary from below 0.5 m/s² up to a short-term maximum value.

It is recommended to use the values specified in the table when calculating the vibration values according to ISO/TR 25398:2006. At the same time the actual use conditions have to be taken into consideration.

Telescopic loaders, like wheel loaders, are to be classified by operating weight.

Type of loader	Typical operating conditions	Average value			Standard deviation (s)		
		$1.4 \cdot a_{w,eqx}$ [m/s ²]	$1.4 \cdot a_{w,eqy}$ [m/s ²]	$a_{w,eqz}$ [m/s ²]	$1.4 \cdot s_x$ [m/s ²]	$1.4 \cdot s_y$ [m/s ²]	s_z [m/s ²]
Compact wheel loader (operating weight < 4,500 kg)	Load & carry (load and transport work)	0.94	0.86	0.65	0.27	0.29	0.13
Wheel loader (operating weight > 4,500 kg)	Load & carry (load and transport work)	0.84	0.81	0.52	0.23	0.2	0.14
	Application in extraction (harsh application conditions)	1.27	0.97	0.81	0.47	0.31	0.47
	Transfer drive	0.76	0.91	0.49	0.33	0.35	0.17
	V-operation	0.99	0.84	0.54	0.29	0.32	0.14

1160 Dimensions

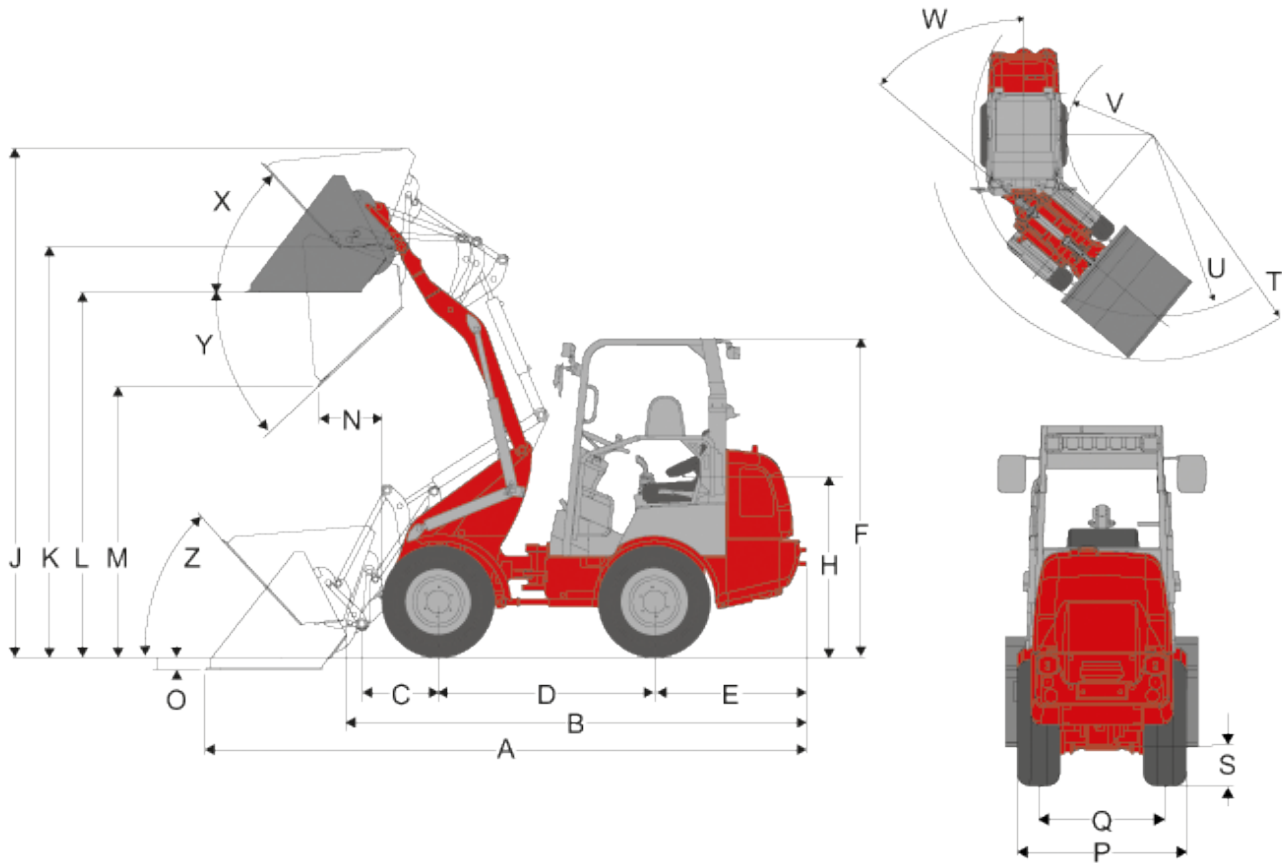

		1160 (FSD)	1160 (Kabine)
A	Total length	3,983 mm	3,983 mm
B	Total length (without bucket)	3,005 mm	3,005 mm
C	Axle middle to bucket pivot pin	508 mm	508 mm
D	Wheelbase	1,468 mm	1,468 mm
E	Rear overhang	917 mm	917 mm
F	Height to top of overhead guard fixed	2,237 mm	
	Height to top of overhead guard foldable (eps)	2,341 mm	
	Height to top of overhead guard foldable, folded (eps)	1,928 mm	
	Height to top of cabin		2,302 mm
H	Seat top height	1,273 mm	980 mm
J	Total working height	3,423 mm	3,423 mm
K	Height of bucket pivot (max.)	2,740 mm	2,740 mm
L	Load-over height	2,421 mm	2,421 mm
M	Dumping height	1,799 mm	1,799 mm
N	Operating distance for M	498 mm	498 mm
O	Digging depth	97 mm	97 mm

P	Total width	1,044 mm	1,044 mm
Q	Track width	780 mm	780 mm
S	Ground clearance	255 mm	255 mm
T	Maximum radius external	2,592 mm	2,831 mm
U	Radius at the outer edge	2,138 mm	2,415 mm
V	Inside turning radius	1,017 mm	1,311 mm
W	Inclination angle	50 °	43 °
X	Rollback angle at max. lifting height	50 °	50 °
Y	Dumping angle (max.) (max.)	40 °	40 °
Z	Rollback angle (on the ground)	49 °	49 °

eps (Easy Protection System) = fold-down canopy

1160

Hoftrac

1160 Standard components

Engine

- Perkins 403 J-11 (18,4kW / 25 HP), Stage V

Drive

- Compact axle K80
- Automatic drive via oil engines on the axles, travel direction can be selected via the joystick
- Service brake: Hydrostatic drive system acting on all 4 wheels (wear-free)
- Central service and parking brake in the drive train acting on all 4 wheels
- Tyres 10.0 / 75 - 15.3 AS ET10

Steering

- Hydraulic articulated pendulum steering, 12° oscillating angle

Hydraulics

- 3rd Control circuit front DN10
- Hydraulic oil cooler
- Lock for steering valve
- Floating position for lift and tilting cylinders

Driver's cab

- Canopy with retaining system ROPS / FOPS tested, driver's cab can be tilted to the side
- Comfort seat with safety belt, fully suspended, weight, back and horizontal adjustment, 60 mm spring deflection
- Joystick with travel direction switch

Other

- Working lights (2 front, 1 rear)
- Operating hour meter
- Battery circuit breaker

- Fuel display
- Mechanical quick-change system for attachments

1160

Hoftrac

1160 Options

Engine

- Engine pre-heating

Driver's cab

- Right armrest
- eps (Easy Protection System) - fold-down canopy
- Cab
- Adjustable steering column
- Air-suspended comfort seat

Lighting

- Working light on loading arm
- Lighting according to Road Traffic Regulations
- Rotary beacon

Axles / drive

- T80, including transfer gear and universal joint shaft
- T94 including transfer gear and universal joint shaft (high pressure drive system)
- 100% differential lock (only for axle T80 and T94)
- Wheel spacer (30 mm)
- Speed increase to 30 km/h

Hydraulics

- Unpressurised reflux (front)
- 3rd control circuit front DN12
- 3rd comfort control circuit
- 4th comfort control circuit
- High flow single-acting (65 l/min)
- Faster plug-in connector (machine or attachment side)
- Notch for joystick (single / double)
- Hydraulic connection in rear (single-acting or dual-acting)

Electrical connections

- Plug receptacle in front, 3 or 7-pin (single or dual function)
- Plug receptacle for rear attachments, 7-pin

Other

- High lifting height
- Hydraulic quick-change system for attachments
- Counterweight (floor panel)
- Weight of cast iron rear
- Back-up alarm
- Load-lowering valve
- Combination case with warning triangle and first-aid kit
- Switch position indicator
- Self-recovery coupling
- Tool box
- Technical Inspection Authority expert's report
- Central lubrication system
- Custom made paint finish

Please note: that product availability can vary from country to country. It is possible that information / products may not be available in your country. More detailed information on engine power can be found in the operator's manual; the stated power may vary due to specific operating conditions. Subject to alterations and errors excepted. Applicable also to illustrations.

Copyright © 2021 Weidemann GmbH.